

T M 1 0 0 0

T R A Y M A K E R / P A C K E R

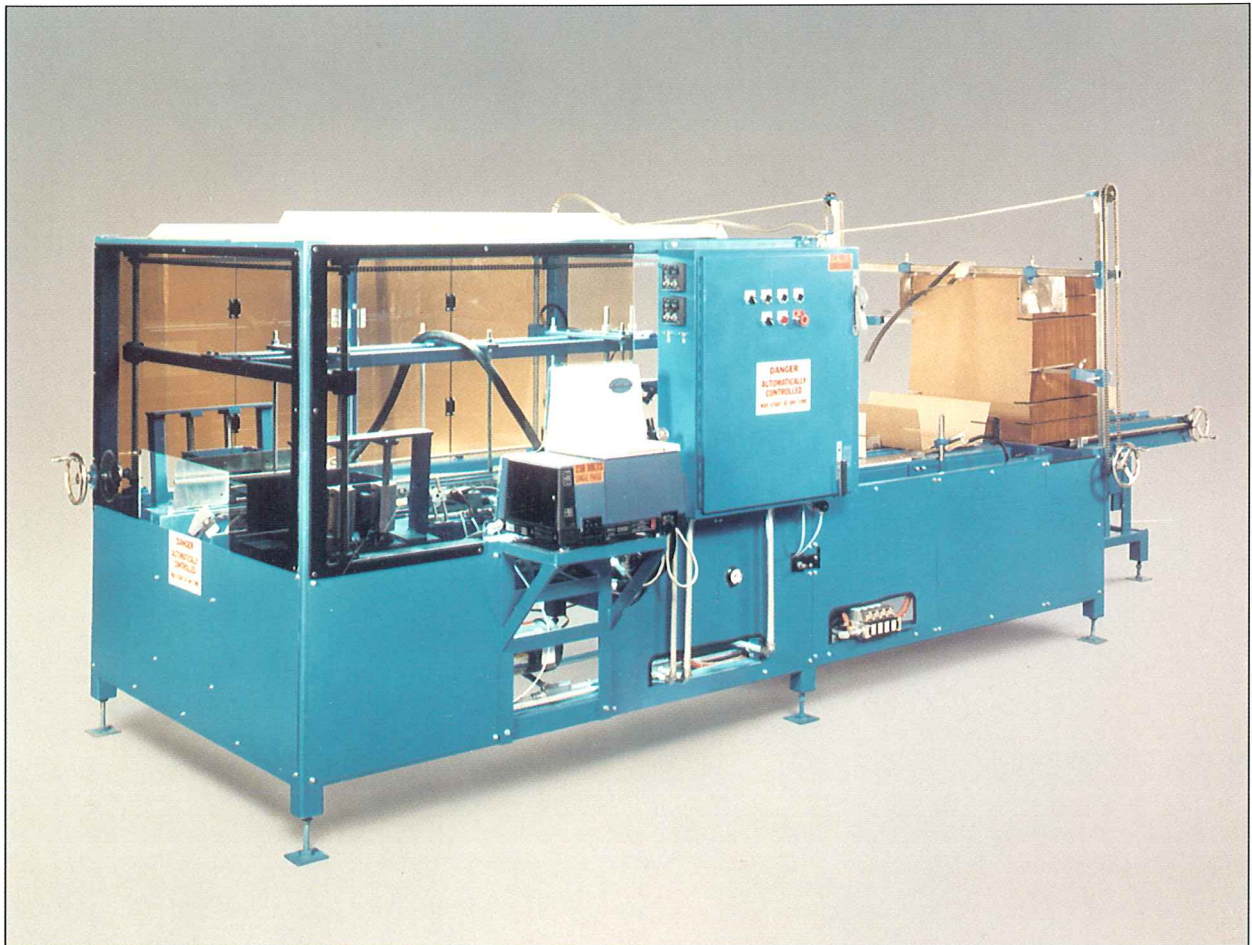

Will erect blank, accumulate product, load and seal tray or case blanks for a variety of canned or cartoned products. Converts in minutes to make complete wrap around type cases.



COMPACKER

The TM 1000 is a custom engineered automatic tray/case blank packing machine or trayformer only. The machine's efficient design is tailored to your particular requirements and allows the capabilities of tray/case blank erecting, product accumulation, loading and sealing. Changeover can be accomplished in a matter of minutes, with most adjustments made using handcranks and no special tools.

Through the use of production tested designs, backed by over 30 years of Compacker experience and proven performance, the TM 1000 provides

optimum productivity. Like all Compacker equipment, it is engineered to meet your exact needs to reduce labor costs and improve line speed.

FEATURES

- Fully automatic operation
- Choice of tray or case blank styles
- Convertible from traymaker to tray or case blank/loader/sealer
- Easy changeover with most adjustments made by handcranks and requiring no special tools
- Accumulates and loads product in a variety of pack patterns
- Accepts product in an assortment of shapes and sizes

- Traymaker only requires no forming mandrel
- Easy-to-load large capacity blank magazine
- Speeds up to 20 trays per minute, depending on line speed and product size
- Intermittent motion main drive
- Hot melt closure
- Compact, rugged structural steel construction
- Electrical controls with PLC logic
- Common sense construction and easy maintenance procedures
- Many options available according to customer needs

TRAY BLANK

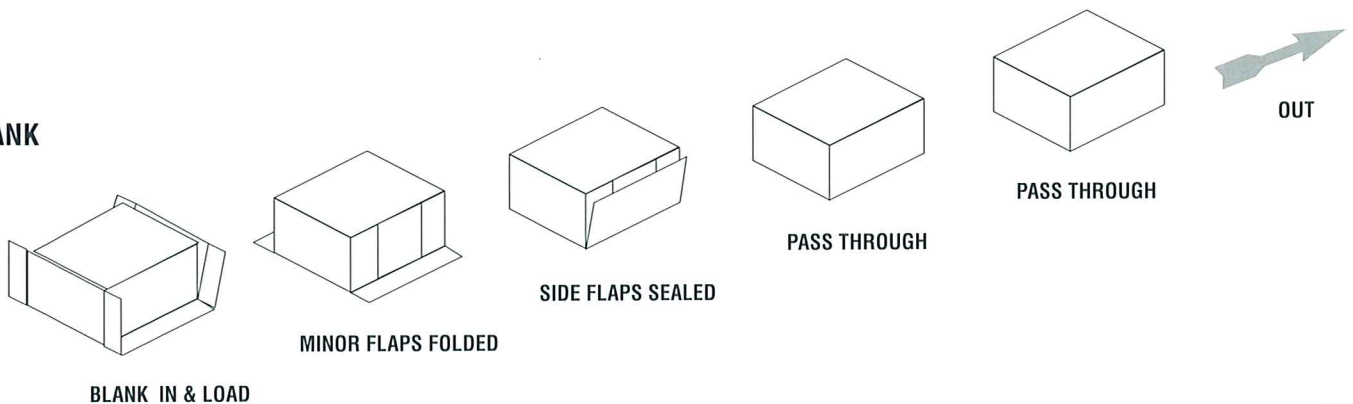

OPTIONAL CASE BLANK CAPABILITY

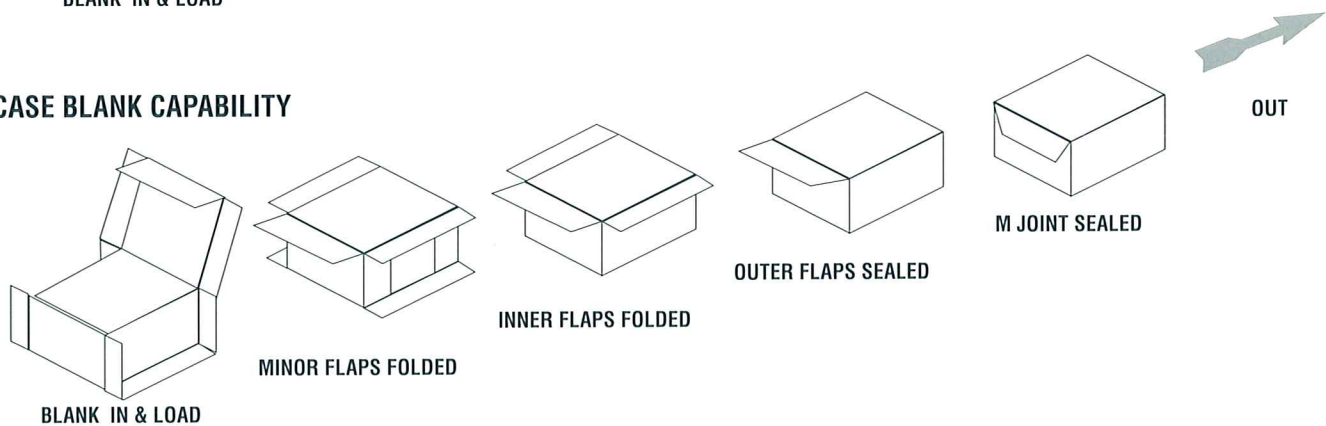

COMPACKER SYSTEMS LLC
EASE PACKAGING SYSTEMS
Established 1961
 9104 N. Zenith-52806
 P.O. Box 2026
 Davenport, Iowa 52809-2026
 Ph: (563) 391-2751
 Fax: (563) 391-8598
 www.compacker.com

